

PT CAST

The vacuum pressure casting machine for platinum

With a melting chamber that can melt **up to 500 gr of platinum** at each cycle in an Argon gas-controlled atmosphere, the PT Cast delivers an **excellent product with a smooth surface finish**.

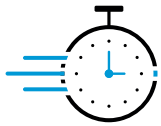

EXTREMELY FAST

The new improved **induction system heats the metal directly**, making the casting process much faster.



EASY TO USE

Increased control thanks to an interactive touch screen, that allows to save customized programs.



WATER COOLING

The water-cooling system of the crucible and melting chamber **enables continuous operation and allows temperature stabilisation**.

*dimensions in mm

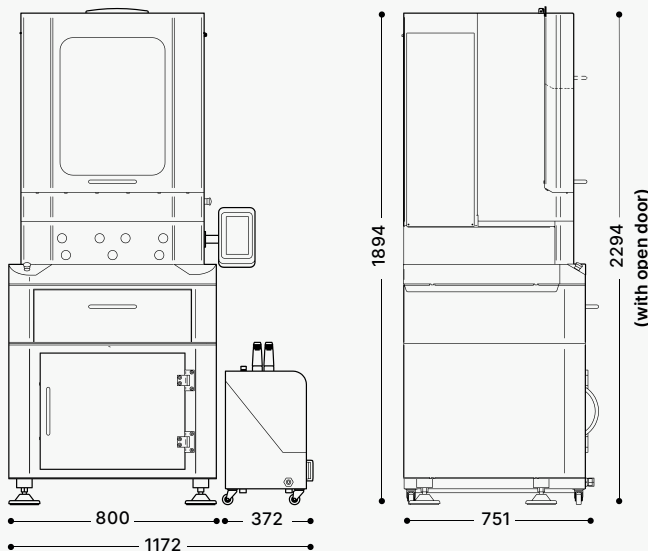

Discover all our machines, stay connected!



REQUEST A QUOTE

sales@orotig.com

more information on orotig.com

FEATURES

MADE IN ITALY



Quick Controls

Main controls in manual mode to facilitate operating the machine with gloves. Once the parameters are set, the buttons allow to complete a cycle without using the touch screen.

Large chamber

Melting chamber that can melt up to 500 gr of platinum.

Touch screen

7" colour display with intuitive interface, possibility to set customised programs and check the parameters during the cycle.

TECHNICAL DATA

PT Cast

GENERATOR TYPE	Inverter
POWER SUPPLY	220/400 VAC±10%, 50/60 Hz, 3P + N + PE, 5.5 kW
TYPE OF PROCESS	Inductive
TYPE OF METAL	Platinum
MAXIMUM METAL QUANTITY	500 gr
MAXIMUM FLASK SIZE	Ø= 130 mm, H= 170 mm
MINIMUM INERT GAS PRESSURE (ARGON)	1.5 bar
MAXIMUM TEMPERATURE	1900°
WORK CYCLE	Up to 6 / hour
COOLING SYSTEM	Forced ventilation and liquid cooling
DISPLAY	Touch screen 7"
WEIGHT	400 Kg

Continuous cycle

Thanks to a completely redesigned water-cooling system, the PT Cast can work on a continuous cycle, **stabilising the melting temperature and achieving an excellent product with a smooth surface finish.**

