

evoX TECH

Perfect welds, no compromises

Orotig presents Evo X Tech: the upgraded version of the industry-leading Evo X laser welder sets a new benchmark with the **innovative SoftSpot technology** and an **optimized working cycle**, positioning itself as a frontrunner in **performance and efficiency** within the welding industry.



ENHANCED PERFORMANCE

With an enhanced cooling system, Evo X Tech can sustain a **continuous working cycle** while upholding the highest standards of welding quality.



SOFT SPOT

With the new SoftSpot technology, Evo X Tech can achieve **clean and spatter-free welds** even on reflective materials thanks to soft, adjustable and uniform shots.



TOP PERFORMING ON ALL METALS

With a maximum power of 250 J and a peak power reaching 10 kW, Evo X Tech ensures exceptional welding quality, particularly on reflective metals like **silver, white gold and platinum**.

Performance and quality

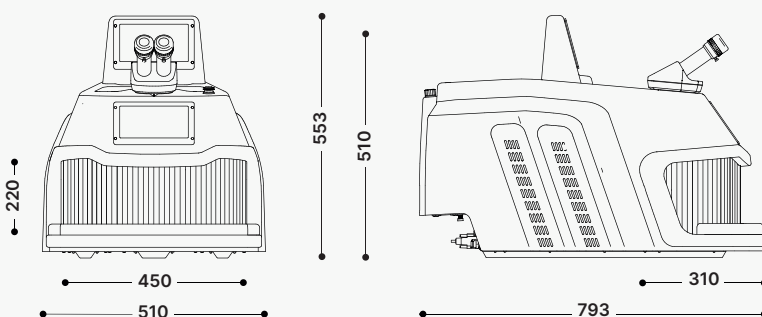

*dimensions in mm

Discover all our machines, stay connected!



REQUEST A QUOTE

sales@orotig.com

more information on orotig.com

FEATURES



MADE IN ITALY

Leica microscope

Leica 45° stereo microscope with 10x optical zoom and right-eye crosshair.

IUVAPS™ Sanitizing system

Constant sanitisation of the environment thanks to the IUVAPS™ system, which eliminates dust and pathogens.

Wide welding chamber with adjustable LED

Welding chamber with wide access and patented, adjustable LED lighting system to facilitate welding on reflective metals.



Intuitive interface

7" touch screen with colour IPS display and 75° viewing angle.

Ethernet

Telemetry for easy assistance and remote updates.

Preset programs

Possibility of viewing and recording machining operations and dynamically setting the work program, choosing it from a library of preset programs.

Smart Footswitch

The device performs all the function of the traditional pedal functions and allows parameter adjustment via pressure variation on the pedal, without workflow interruption.

TECHNICAL DATA

Evo X

CRYSTAL TYPE	Nd:YAG @ 1064
PULSE POWER	250 J
PULSE DURATION	25 ms
PEAK PULSE POWER	10 kW
AVERAGE POWER	90 W
PULSE FREQUENCY	0 - 40 Hz
POWER SUPPLY	115 - 230 VAC ± 10%, 1P + N + PE, 50/60 Hz, 1.8 kW
FOCAL DIAMETER	0.1 to 2 mm
COMMAND ACCESS	External with 7" capacitive touch screen display, internal with rotary switch
COOLING SYSTEM	Liquid cooled (4 L) with forced ventilation
WEIGHT	41 Kg

ACCESSORIES



DYNASCOPE HEAD



ADJUSTABLE MICROSCOPE STAND (5° - 25°)



PNEUMATIC PEDAL



INTERNAL WRIST REST



MOTORISED TABLE